



# AP4000 Heading Control System

# Introduction

Navis Engineering, established in 1992, is a recognized expert in ship automation systems and one of the few world experts in dynamic positioning technology. After more than 18 years of scrupulous research and development we have cultivated a profound understanding of every customer's needs, as well as of market trends in shipbuilding. Our company's mission is to keep our systems as simple and user-friendly as possible, and, at the same time, to preserve the high level of quality and reliability.

The AP4000 Heading Control System is the new generation of autopilots manufactured by Navis Engineering. It is a modern and technologically advanced digital ship control unit that is intended to reduce the operator's workload, increase the vessel motion efficiency and improve operational safety.

The AP4000 autopilot has been substantially redesigned. The front panel has been modernized and configured as a 6.5' high contrast and resolution color display with a 150° viewing angle. Additionally, the level of front panel protection has been increased from IP44 to IP67, which makes the AP4000 suitable for outdoor installations (at fly-bridge or port/starboard wings).

The system has been designed as a flexible solution, which makes it possible to install the AP4000 on a broad range of vessels easily, ranging from yachts and small boats to VLCCs.

The AP4000 is one of the few autopilots designed for vessels with 2 independent rudders.

Our company ensures easy and prompt integration of the AP4000 with existing Navis systems onboard, whether the autopilot is supplied as part of a package or retrofitted..

DNV MED-B and MED-D type tests of the AP4000 are pending



The modular concept of the AP4000 control panel makes it possible to integrate the autopilot into any bridge console without causing any harm to the overall design.

The autopilot is frame-mounted, which allows the control panel to be detached from the bridge console easily, in case that is necessary.

Compared to the previous generation's autopilot, the level of the control panel's front surface protection has been increased from IP44 to IP67, which makes the AP4000 suitable for outdoor installations (at fly-bridge or port/starboard wings).

The reduced number of buttons ensures prompt and easy access to all the functions of the AP4000.



The AP4000 presents a 6.5' high-resolution anti-glare color LCD display and a 150° viewing angle. The user-friendly GUI complies with all the industry ergonomic standards and is very easy to read and operate. Day and night color palettes are available

Particular attention has been paid to offer simple and intuitive operation of the system. All information, such as alarms, the heading set and the heading steered, the commanded and the actual rudder angles, the rate of turn, ship speed or position, are clearly shown in easy-to-read pages.

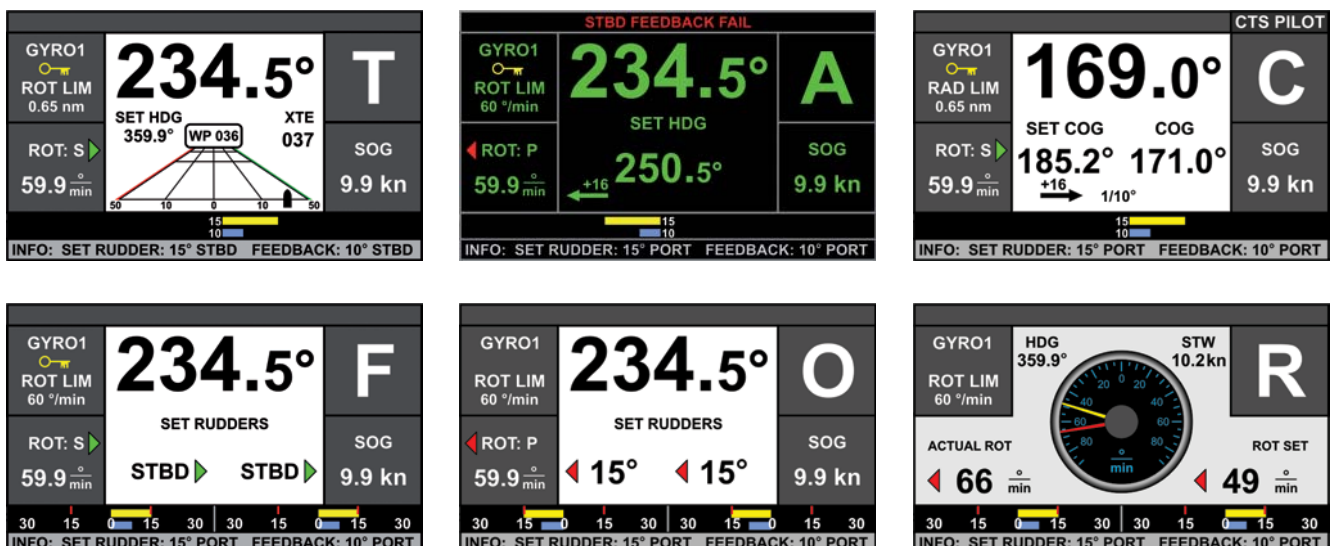



# System overview

As compared to the AP3000, the software part of the AP4000 has been upgraded significantly. Up to five network control panels have been added to functionality. The use of only one 'Sensitivity' parameter for fine-tuning system performance covers all known yawing, steering and counter rudder settings of the autopilots of other brands.

The AP4000 has built-in 'Heading Monitor System' (HMS) functionality, which makes it possible to receive and monitor the data coming from two heading data sources continuously (gyro+gyro, gyro+magnetic compass, gyro+fluxgate etc.). Several speed sources can also be used during operation (GPS, waterspeed log or bottom tracking log).

The AP4000's fully self-adjusting 'Auto Tune' algorithm allows it to easily adapt the autopilot performance to the hydrodynamic parameters of any vessel, irrespective of its displacement and dimensions. This makes it possible to use the AP4000 onboard any commercial or leisure vessel with a single rudder, linked rudder, independent rudder or stern azimuth Z-drives configuration.

## AP4000 steering gear interfaces:

- Solenoid valves, 24V DC (up to 3A load current)
- Proportional valves – 0...10 V,  $\pm 10V$  or 4...20mA control signal
- Proportional rudder control (steering gears with follow-up steering control system) – 0...10 V,  $\pm 10V$  or 4...20mA control signal

## Sensor interfaces

- GPS
- Gyrocompass
- Log
- VDR
- Second gyro or magnetic compass
- ECDIS/ECS



Three more control modes have been added to those present in the previous generation of the AP4000: the 'CTS Pilot' control mode, which allows for steering by a pre-set COG value, the 'Windvane' mode for sailing yachts, making it possible to steer by setting the relative wind angle, and the 'River Pilot' mode, allowing the operator to steer the vessel by a pre-set ROT value using an external ROT tiller or the knob in the control panel.

The following control modes are available:

## Auto

In the 'Auto' mode the ship heading is controlled automatically with minimum rudder activity

Wind/Current

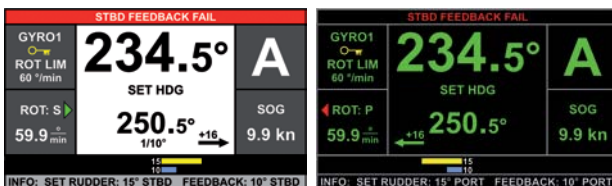
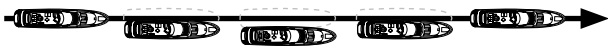

## Track/AutoNav

In the 'Track' mode the AP4000 automatically controls the vessel heading on straight legs between waypoints using NMEA messages from a Category A/Category C track control system (ECS/ECDIS/Chart Plotter).

Supported NMEA messages: APB, BWC, HTC, HTD, HSC.

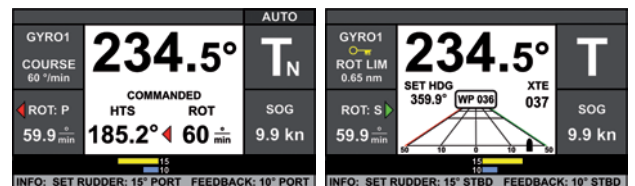
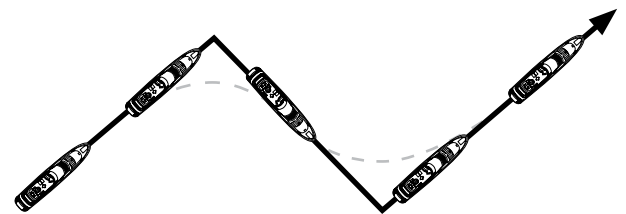

## CTS Pilot

The 'CTS' mode allows the vessel to stay on a preset course over ground. The drift/wind force and direction are not taken into account.

Actual heading - 45°

Wind/Current

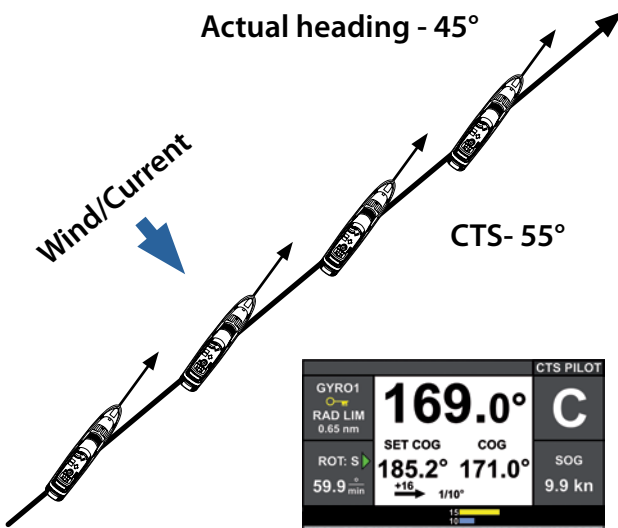

## River Pilot

In 'River Pilot' turns are performed by a preset 'Rate of Turn' value using an external ROT tiller or the knob in the control panel.

ROT/RAD

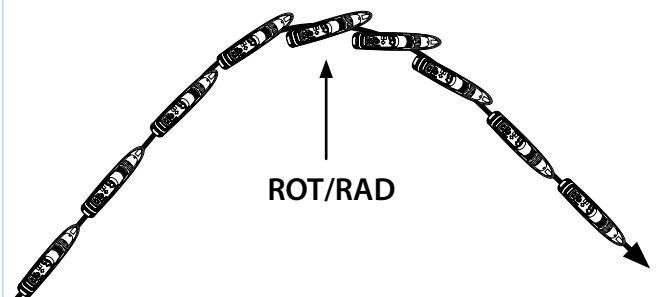

# Control modes

## Dodge/FFU Override/FFU

In 'Dodge'/'FFU'/'FFU Override' modes the heading can be corrected manually using the external override devices (rotary knob on the AP4000 control panel, override tiller, jog lever, etc.). These modes are optional.

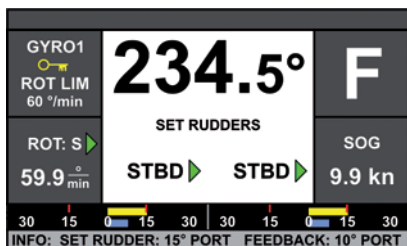
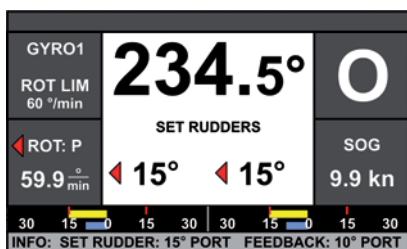
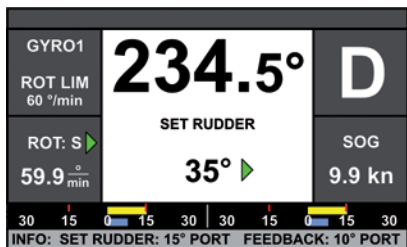

## Windvane (for sailing yachts)

The 'Windvane' mode allows for steering the sailing yacht by setting the relative wind angle.

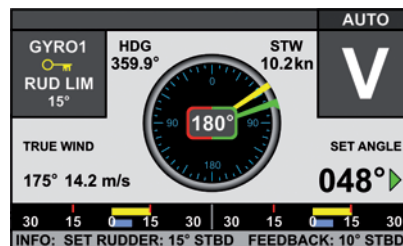
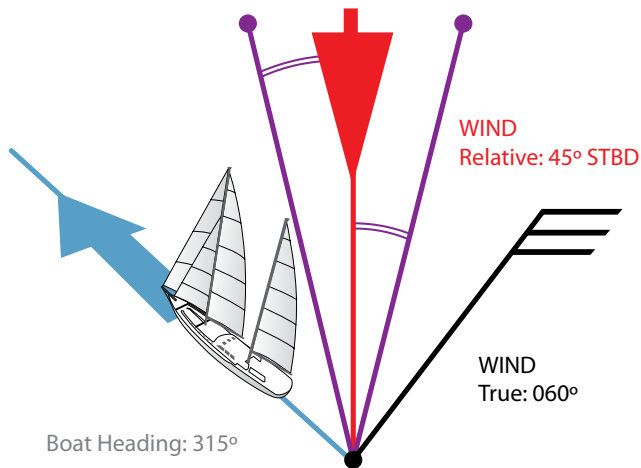

## Service and Support

Wherever you are on the globe, Navis Engineering offers you a comprehensive package of technical support 24/7 x 365 days a year. The combination of extensive built-in diagnostics, hot-line support, a network of service agents with Navis Engineering certified field service engineers, and our service center with senior engineers ready to fly to your vessel within 24 hours, no matter where it is located, ensures a timely response to any technical problem.

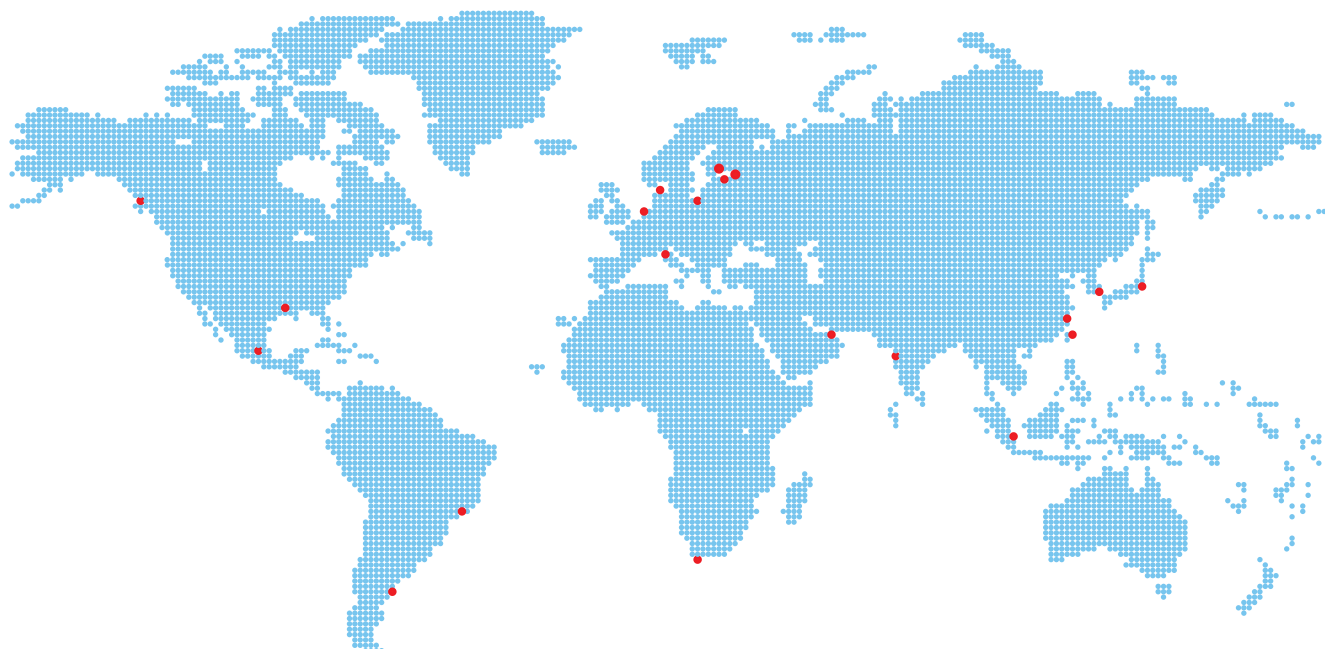

## AP4000 delivery set

- AP4000 operator unit
- Control units
- Documentation set
- Spare parts set

## AP4000 optional features

- Mode switch selector
- Rudder feedback unit
- FFU override control unit (including PCB, box and tiller)
- VDR/central alarm panel interface (including PCB and box)
- Rudder angle and order indicators

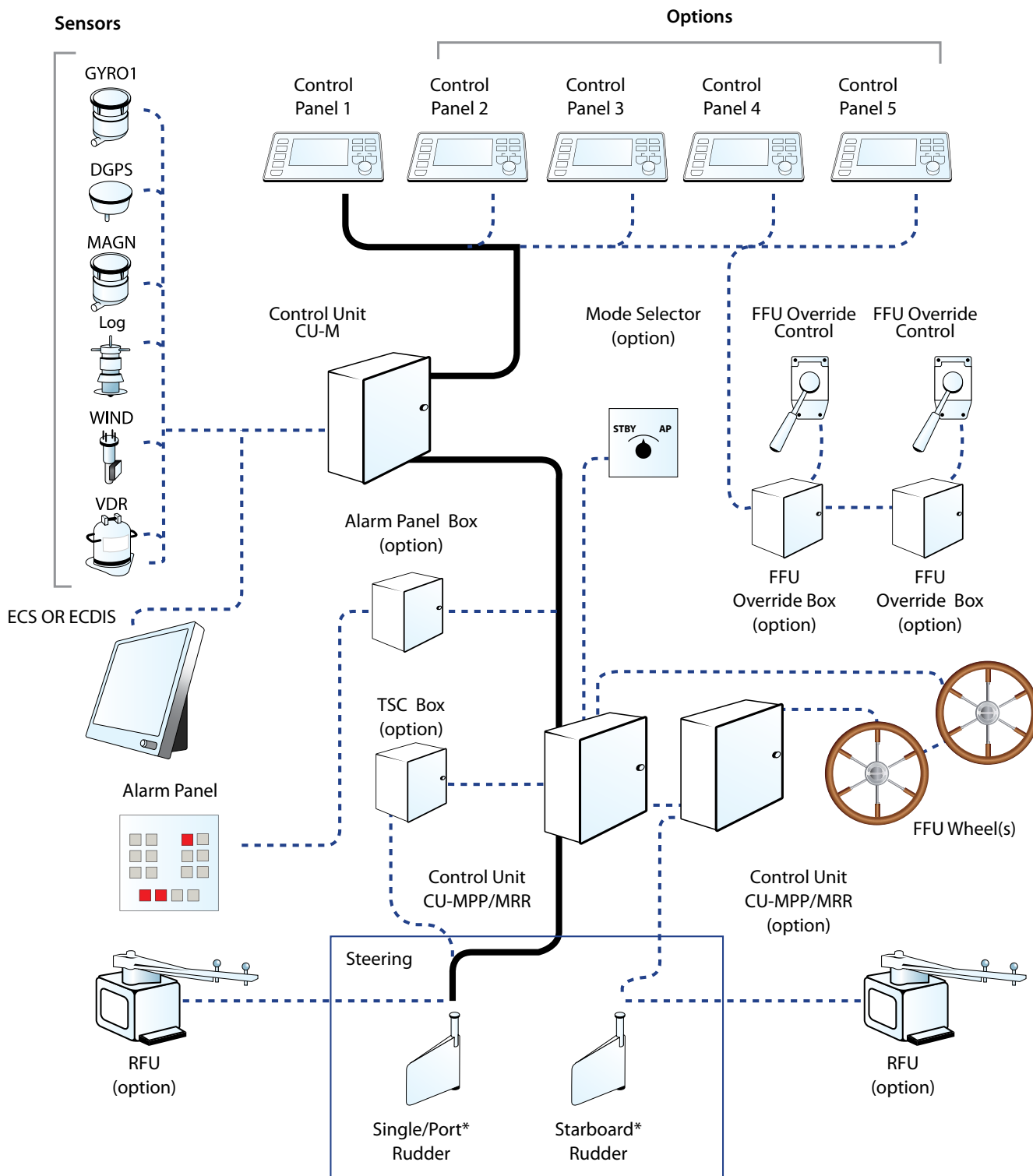

\* Note: Depends on ship configuration

# General Technical Information

## Power Supply:

- 24 VDC +30% ... -25%
- APH4000 power supply is backed up with a +12V battery

## Operating and Storage Conditions:

### Operating Conditions:

- Temperature - -25...+75°C
- Humidity - Up to 95% at 25°C
- Up to 75% at 45°C

### Storage Conditions:

- Temperature - -30...+75°C
- Humidity - Up to 98% at 25°C
- Up to 75% at 45°C

## Steering Gear Interfaces:

- Direct control of solenoid valves, 24 VDC (up to 3A load current).
- Direct control of proportional valves - 0...10 V, ±10V or 4...20mA control signal.
- Proportional rudder control via existed Full-Follow-Up Steering Control System) - 0...10 V, ±10V or 4...20mA control signal.

## Sensor Input & Output:

### Input:

- ECDIS/ECS (Track Control mode)
- TCS Category A. - \$-APB, \$-BWC
- TCS Category C. - \$-HTC/\$-HTD or \$-HSC

### Heading

- Gyro compass - \$-HDT (Recommended), \$-THS
- Magnetic compass - \$-HDG, \$-HDM

### Speed

- Log (STW) - \$-VHW, \$-VBW (Recommended)
- GPS (SOG) - \$-VTG, \$-GGA
- Manually input available

### Wind

- \$-MWV(R), \$-MWV(T), \$-MWD, \$-VWR - For Sailing Yachts in Wind Vane control mode

### Output:

- \$AGHTD, \$AGRSA, \$AGHDT
- Input and Output data communicates via standard serial RS422 protocol (via RS232 protocol - optionally).

## Display characteristics:

- Technology - Wide VGA
- Pixel resolution - 800\*480
- Active display area - 143.4 (H) x 79.2 (V) mm
- Contrast ratio - 400:1
- Viewing angle (typical) - 75 deg (left/right) and 70 deg. (up/down)
- Backlighting - adjustable

## Technical Data:

- Dimensions - 288\*288\*52 (without knob and rear connectors) mm
- Power Supply Voltage - 24 V +30%...-25%, (APH4000 is backed up with +12V Battery)
- Electrical isolation - Isolation from computing core and external ports.
- Isolation Voltage - 1000V
- Data Exchange Interfaces - CAN 2.0B, transmission rate up to 500kb/sec
- Acoustic alarm - not less than 75dB (A) pressure at a distance of 1meter.
- IP67 on top, IP22 - rear side.

## CU-M Technical data:

- Dimensions - 300\*200\*120mm (without glands and mounting brackets)
- Data Exchange Interface - CAN 2.0B, transmission rate up to 500kb/sec

CU-M includes APM3000, Central control module modules.

CU-M components are located on the mounting panel inside damp-proof steel enclosure, made in accordance with IP55 degree of protection. Connection to external circuits is made through sealing glands.

CU-M weight - 4.7 kg

## CU-MPP/MRR Technical data:

- Dimensions - 400\*400\*120mm (without glands and mounting brackets)
- Data Exchange Interface - CAN 2.0B, transmission rate up to 500kb/sec

CU-M includes APP3000 and APR3000 PCB's: Steering System and Steering Gear control modules.

CU-MPP/MRR components are located on the mounting panel inside damp-proof steel enclosure, made in accordance with IP55 degree of protection. Connection to external circuits is made through sealing glands.

CU-MPP/MRR weight - 11.1 kg

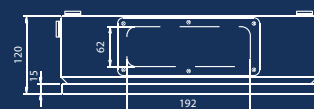
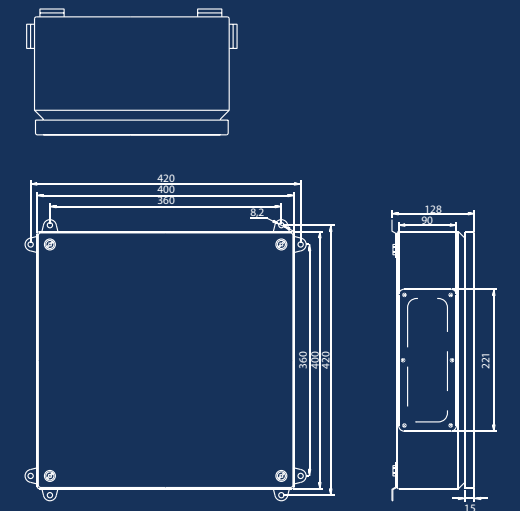
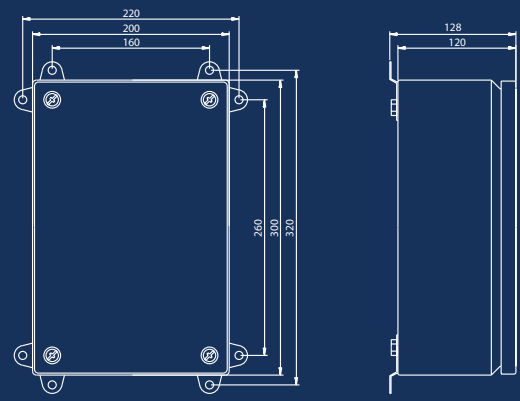
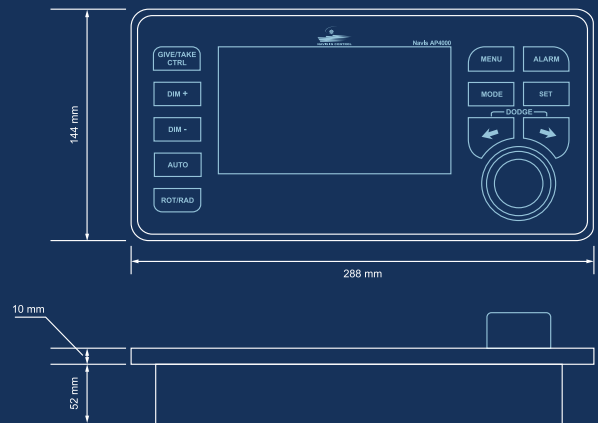

## Headoffice

Navis Engineering Oy  
Tuupakantie 3A, FI 01740  
Vantaa, Finland  
Tel:+358 9 250 9011  
Fax:+358 9 250 9012  
e-mail: [headoffice@navisincontrol.com](mailto:headoffice@navisincontrol.com)  
<http://www.navisincontrol.com>

## R&D Center

Navis Ltd.  
Detskaya str., 5a, 199106  
Saint-Petersburg, Russia  
Tel:+7 812 322 67 15  
Fax: +7 812 322 67 35  
e-mail: [sales@navisincontrol.com](mailto:sales@navisincontrol.com)  
<http://www.navis.spb.ru>

## China Office

Navis China  
Shibei Hi-Tech park  
JiangChang three road,building 78,room 603.  
ShangHai 200436,China  
Tel: +86 21 36355718  
Fax: +86 21 36355728  
Contact person: James Li  
e-mail: [li.pengfei@navisincontrol.com](mailto:li.pengfei@navisincontrol.com)  
Mobile : +86 13501777440